

EXTENSION SPINDLES

MOD. 4010	h = 1m	DN 50-400
MOD. 4015	h = 1,5m	DN 50-400

Rigid extension spindle for RACI gate valves
model 1041-1042-1051-1100-1200-1201-1300

h = PIPE COVER DEPHT

SPECIAL FEATURES

- Hard wearing design and easy installation.
- Connection by square cap on gate valve spindle with locking pin.
- Valve insertion directly on protection tube by bell shaped connection, that follows the profile of the cover.
- PE outer protection pipe.

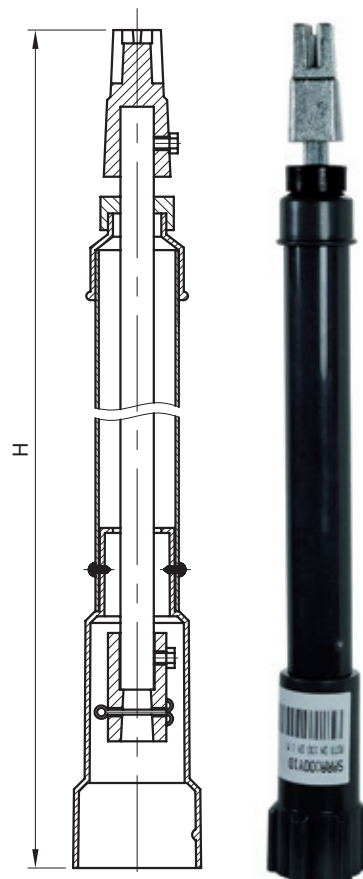

MOD. 4110	h = 1m	DN 3/4" - 2"
MOD. 4115	h = 1,5m	DN 3/4" - 2"

Rigid extension spindle for RACI service valves
model 2250-2252-2253-2260-2312-2313-2500.

MOD. 4308	h = 0,85-1,15m	DN 3/4" - 2"
MOD. 4310	h = 1,05-1,50m	DN 3/4" - 2"
MOD. 4313	h = 1,30-1,80m	DN 3/4" - 2"
MOD. 4316	h = 1,60-2,70m	DN 3/4" - 2"

Telescopic extension spindle for RACI service valves
model 2250-2252-2253-2260-2312-2313-2500.

h = PIPE COVER DEPHT.

SPECIAL FEATURES

Rigid type:

- Connection by square cap on gate valve spindle and bell on protection tube threaded to be screwed on valve cover.
- PE outer protection pipe.

Telescopic type:

- Connection by square cap on service valve spindle and bell on protection tube threaded to be screwed on valve cover.
- PE outer protection pipe.
- Quickly and simple adjusting to ground level by pushing or pulling the tube and spindle shaft.
- Compensation for any failure of the soil to prevent damage to the maneuver transmission.
- Complete with support for base plate.

