



MOD. 5500 | **PN 10** | **DN 2"**

Male threaded connection.

MOD. 5501 | **PN 10** | **DN 50/80/100**

Flanged connection (multiple bore DN 80-100).

SPECIAL FEATURES

- Double orifice type, fully automatic triple function for releasing air during filling the pipe and bringing air in (anti-vacuum) during emptying the pipe, releasing air under pressure.
- Realized by non-corrosive material.
- Performances according to the requirements of EN 1074.
- Compact version to obtain small dimensions.
- Special design allowing the application with liquids carrying solid particles such as sewage and effluent, by creating an air gap between the wastewater and the sealing system of the air valve.
- Minimum operating pressure for watertight: 0,5 bar.
- On request, complete with on/off ball valve DN 2".

MATERIALS

Body, lower float, stem and internal mechanism:
Stainless steel 1.4301/ EN ISO10088 (correspondent to AISI304)

Upper air release unit:
Polyamide PA fibre glass reinforced

Upper float:
Polypropylene foam

Gasket:
NBR rubber

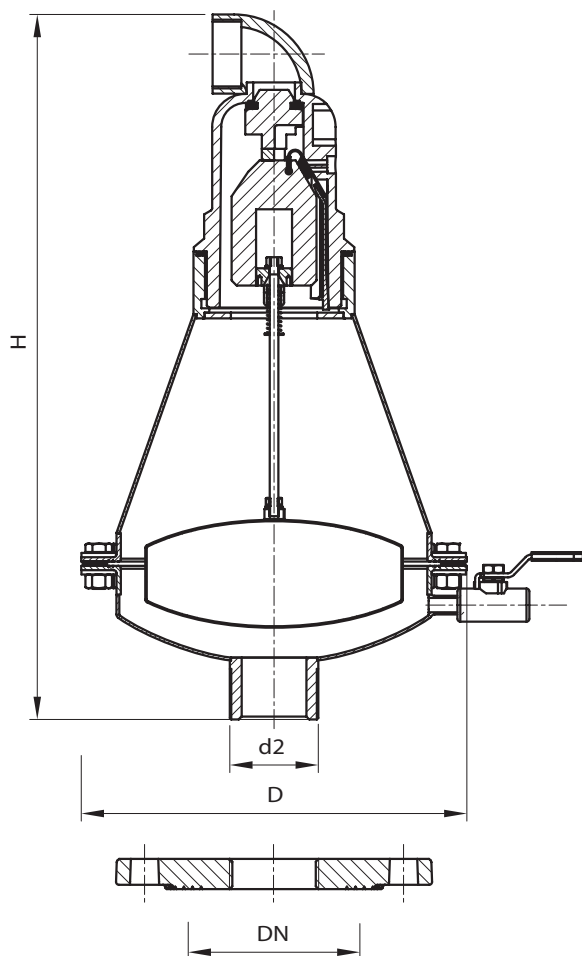

d2/DN	PFA	D	H	Weight (kg)
2"	0,5-10	268	490	7
50/80/100	0,5-10	268	490	9,25

All metal, rubber, and coatings used have been designed for contact with water for human consumption, pursuant to the terms of Italian Health Ministry decree n° 174, dated 6/4/2004.